

**General description**

The Tabbed duct access doors are available in variety of sizes to suit all requirements. All duct access doors are double-skin construction using Z275 galvanized steel enclosing 25mm fibreglass insulation. Radius tabs on the ductwork access door frame reduce the likelihood of hand injury.

- Tabbed doors come with a fully Z275G galvanized steel coating
- Insulation : High density (45Kg/m<sup>3</sup>) thermal conductivity: 25 °C - 0.035 and 75 °C - 0.044, (GB/T10294-2008).
- High density polyethylene foam seal fixed on the edges of the inside of the outer frame.
- Camlock that ensures sealing by compression.



**Technical specification**

<b>TAB DOOR</b>	<b>Material</b>	Galvanized steel
	<b>Frame thickness</b>	0,9 mm
<b>SEAL</b>	<b>Material</b>	High density Polyethylene (PE)
<b>INSULATION</b>	<b>Material</b>	Glass wool type RWA 45
	<b>Density</b>	45 Kg / m <sup>3</sup>
	<b>Thickness</b>	25 mm
	<b>Fire classification</b>	Non combustible classification A1
	<b>Heat Conductivity</b>	0,035 w / mk
<b>LOCKS</b>	Camlocks	

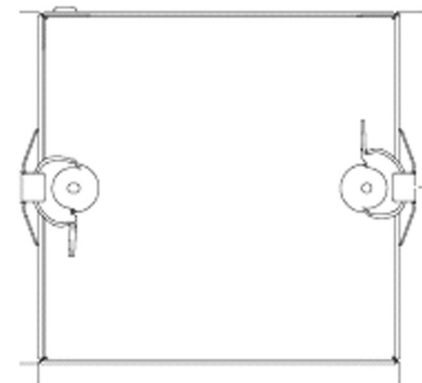

**Standard sizes available**

150 x 150 mm	200 x 150 mm	300 x 200 mm	400 x 200 mm	450 x 300 mm	500 x 500 mm	600 x 600 mm
	200 x 200 mm	300 x 300 mm	400 x 400 mm	450 x 450 mm		

Other sizes available on demand

**Application**

Application is quick and easy. After cutting a hole of more or less 30-32 mm shorter than the size of the used door, you just need to push down the flaps. Afterwards, you need to place the door inside of its frame and tighten the fasteners.

Information contained herein is based on careful tests and experience. It reflects our knowledge and is for guidance purpose only. It is given in good faith and user should ensure that the product is fit for purpose before any application. The quoted values are average and should not be taken as maximum or minimum values for specific purposes. Manufacturer and distributor are not responsible for any non-recommended use or consequential damage.